



Handling Systems

Solutions for Clean Rooms and Hygienic Areas

WWW.SCHMALZ.COM/PALVAC

▶ Vacuum tube lifter PalVac Sprint
Hygienic when handling drums

▼ Vacuum tube lifter PalVac Sprint
Hygienic when handling bags



Clean work – Vacuum tube lifters PalVac Sprint Hygienic

Wherever goods are moved quickly and frequently in clean rooms or hygienic areas, vacuum handling systems take the strain off employees and ensure an efficient flow of materials. The well thought-out design, the use of high-quality components and materials, and the high-quality surface finish of the systems reduce the risk of contamination and at the same time allow the systems to be cleaned quickly and easily.

Solutions for Clean Rooms and Hygienic Areas

APPLICATIONS

- Frequent and fast lifting and moving of workpieces intralogistic processes
- Handling of workpieces such as food products, bags, drums, buckets, canisters, etc. in clean rooms and hygienic areas
- For processes in the food, pharmaceutical, biotech, medical and many other industries



Standard environment with increased hygiene

e.g. goods receiving and dispatch, weighing, dosing, transfilling, intralogistics

JUMBOSPRINT EX – S. 7

Heat treatment in the food sector

e.g. pasteurization, ultra high temperature heating, cooking, frying, baking, grilling, microwaves, infrared treatment

Airlocks

e.g. reloading of workpieces onto clean room pallets

PALVAC SPRINT HYGIENIC – S. 4

Clean room and hygiene areas

e. g. feeding of machines for further processing of workpieces



Handling solution consisting of vacuum tube lifter and crane

SCHMALZ SOLUTION

- Vacuum tube lifter PalVac Sprint Hygienic (1)
- Integrated filter with contamination indicator (2)
- Matching portfolio of stainless steel jib cranes (3)



Metal parts made of stainless steel V2A / SAE 304 are resistant to many cleaning agents

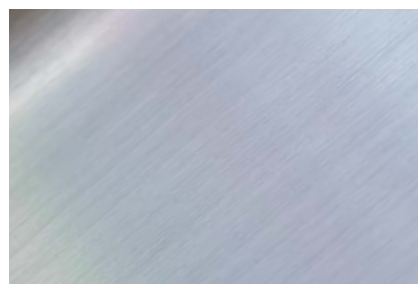

Polished stainless steel surfaces with uniform grain direction prevent adhesions and drain cleaning agents well



Weld seams ground free of cracks and gaps

Vacuum Tube Lifters PalVac Sprint Hygienic

Unique highlights

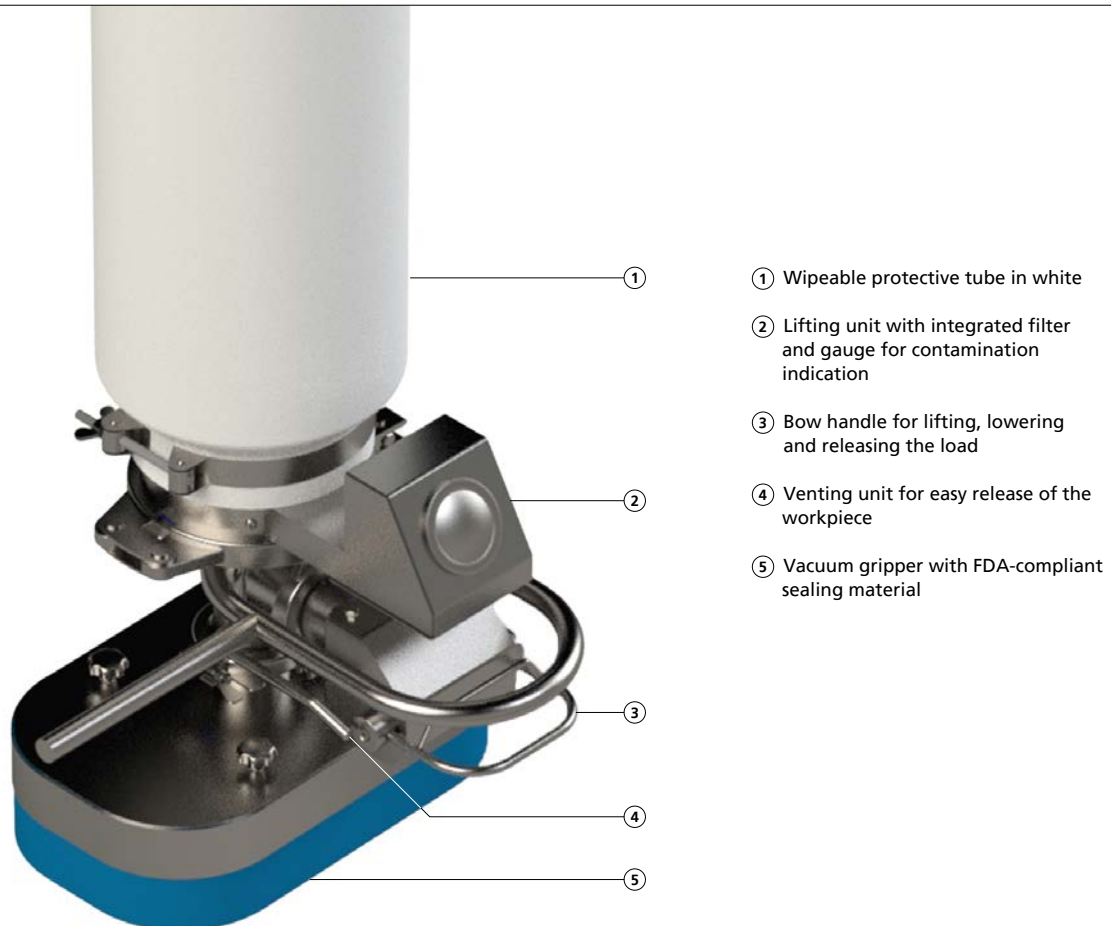

YOUR BENEFITS

01 **Increased productivity**
due to shorter handling and loading times as well as safe and damage-free gripping with vacuum

03 **Hygienic design**
offers almost no possibility for the accumulation of powder/germs and prevents the alteration of the handled goods

02 **Easy and fast cleaning**
due to tool-free disassembly, wipeable protective tube and resistance to many cleaning agents

04 **Avoidance of ambient contamination**
and protection of the lifting tube against internal contamination thanks to integrated filter elements

Vacuum Tube Lifters PalVac Sprint Hygienic

Hygienic design

Where goods are moved quickly and frequently in clean rooms or hygiene areas, the vacuum tube lifter PalVac relieves employees and ensures an efficient flow of materials. Whether bags, drums, food products or other workpieces – the intuitive and ergonomic operation makes the PalVac the ideal helper for depalletizing, machine loading and many other lifting tasks.

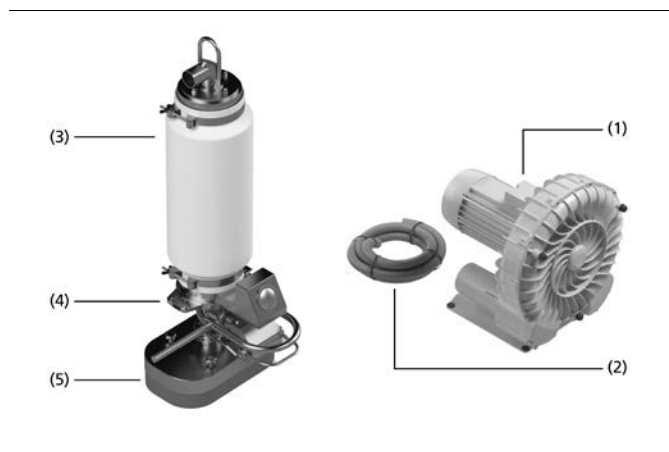

DESIGN

- Vacuum generation (1) by electrical blower up to 50 kg lift capacity
- Flexible vacuum supply hose (2)
- Lifting unit (3) with wipeable protective tube and integrated filter element
- Operator handle (4) with bow-shaped operator handle for lifting, lowering and releasing the load
- Individually matched vacuum grippers (5) for different workpieces

Aufbau Vakuumschlauchheber PalVac Sprint Hygienic

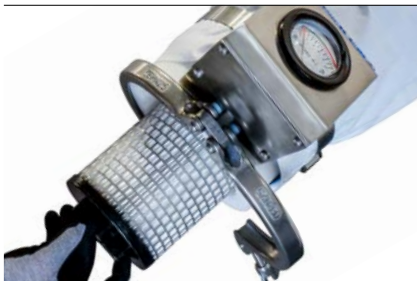

Integrated filter
with differential pressure indicator makes it easy to see the degree of contamination

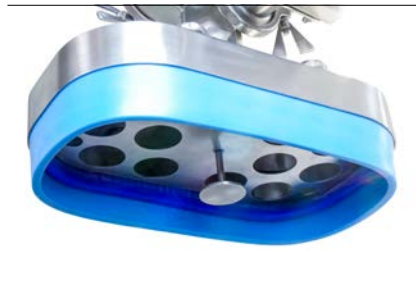

FDA-compliant gripper seals
made of silicone are food safe, non crumbling and non absorbent



Tri-Clamp connections between
lifting unit, operating unit and gripper allow easy cleaning of the tube lifter

TECHNICAL DATA AND CONFIGURATION

- Lift capacity: 50 kg
- Lifting unit length: 1,700 mm / 2,100 mm
- Crane attachment: Articulated arm / standard jib crane
- Filter system: HEPA filter
- Gripper: Sack gripper (oval) / Round vacuum gripper

PalVac Jib Cranes

The optimal ergonomic complement

PalVac stainless steel jib cranes from Schmalz are optimally designed for use with PalVac stainless steel tube lifters in clean rooms and hygienic areas. Different designs allow the cranes to be used in a wide variety of applications and environments.

PRODUCT HIGHLIGHTS

- Optimal adaptation to the nominal load of the tube lifter
- Hygiene-oriented design for low dirt accumulation and easy cleaning
- Durability due to high-quality and low-wear components
- Enables high working speed and positioning accuracy
- Supports ergonomic and fatigue-free work



PalVac crane with articulated jib

- Crane column for floor or ceiling mounting
- Articulated jib in upright version for maximum lifting height or in suspended version for 360° rotatability of the first jib element
- Swivel bearing with swivel angle up to 270°
- Smooth operation adjustable via set screw
- Base plate ready to be dowelled



PalVac crane with conventional jib

- Crane column for floor or ceiling mounting
- Jib with 4,000 mm length and adjustable end stop
- Swivel bearing with swivel angle up to 270°
- Smooth operation adjustable via set screw
- Base plate ready to be dowelled



Crane profile rotated by 45°
reduces deposits



Outside running trolley
for easy cleaning (with conventional jib)

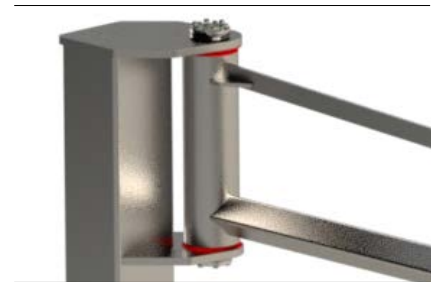

Sealed bearing points
prevent the ingress of contamination

Vacuum Tube Lifters JumboSprint Ex

Safe handling in the explosion protection area



APPLICATIONS

- Efficient handling of loads weighing up to 250 kg in explosion protection zones
- Lifting of bags, drums, cardboard boxes, jugs, buckets and varnish/paint containers
- Preparation and positioning of filled bags, e.g. for emptying into hoppers or mixers
- For use in explosion protection zones 1/21 and 2/22
- Certified according to ATEX 2014/34/EU standard – can be used throughout Europe without country-specific certificate

PRODUCT HIGHLIGHTS

- Operator handle and vacuum grippers made from stainless steel
- All conductive parts are connected with a potential equalization
- Conductive lift tube made from a special material
- Vacuum generator either compressed air driven (ejector up to 85 kg) or electric (blower up to 250 kg)
- Various vacuum grippers in explosion protection design
- Easily change vacuum grippers using the quick-change adapter (optional)
- Complete system for vacuum tube lifter and steel jib crane for explosion protection zone available



- ① Vacuum generator – blower or ejector for special Ex version
- ② Jib crane with steel crane rail
- ③ Vacuum tube lifter JumboSprint EX

AREAS OF APPLICATION

Explosion zone	Vacuum generator	Max. lifting stroke [mm]	Max. lift capacity						
			45 kg	65 kg	85 kg	110 kg	140 kg	200 kg	250 kg
1/21	Ejector	1,700 / 2,100	▶	▶	▶				
2/22	Ejector	1,700 / 2,100	▶	▶	▶				
	Blower	1,700 / 2,100	▶	▶	▶	▶	▶	▶	▶

The Schmalz Group – Worldwide On Site

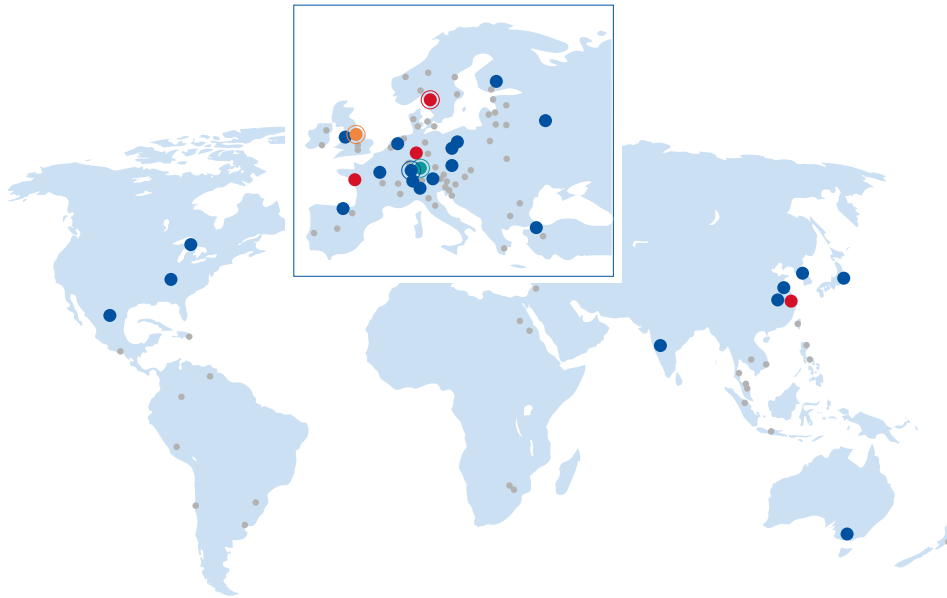

● Germany – Glatten

● International companies:

- Australia – Melbourne
- Austria – Pasching
- Benelux – Hengelo (NL)
- Canada – Mississauga
- China – Shanghai
- China – Taicang
- Czech Republic – Hranice
- Finland – Vantaa
- France – Champs-sur-Marne
- India – Pune
- Italy – Galliate (NO)

● Sales partners

- Japan – Yokohama
- Mexico – Querétaro
- Poland – Bydgoszcz
- Poland – Poznan
- Russia – Moscow
- South Korea – Anyang
- Spain – Erandio (Vizcaya)
- Switzerland – Nürensdorf
- Turkey – Istanbul
- United Kingdom – Manchester
- USA – Raleigh (NC)



● Sweden – Trollhättan

● International companies:

- China – Shanghai
- France – La Haie-Fouassière
- Germany – Staufenberg



● United Kingdom – Chesterfield



● Germany – Stuttgart

Vacuum Automation

WWW.SCHMALZ.COM/AUTOMATION

Handling Systems

WWW.SCHMALZ.COM/HANDLING-SYSTEMS

J. Schmalz GmbH
 Johannes-Schmalz-Str. 1
 72293 Glatten, Germany
 T: +49 7443 2403-0
 schmalz@schmalz.de
 WWW.SCHMALZ.COM

Combina Corporation Ltd.

49/5 Soi Sukhumvit 64, Sukhumvit Road, Prakanong Tai,
 Prakanong, Bangkok 10260 Thailand
 Tel : 02-7416412 to 13, 096-8510482 Fax : 02-7416414



www.combina.co.th
 Email : info@combina.co.th
 Line ID : combinathai